

Charmbe®



LOG SPLITTER

MODEL NO: LOGBUSTER V6

PART NO: 3402150

OPERATION & MAINTENANCE INSTRUCTIONS



ORIGINAL INSTRUCTIONS

LS1218 - ISS 1

INTRODUCTION

Thank you for purchasing this CLARKE product.

Before attempting to use this product, please read this manual thoroughly and follow the instructions carefully. You will find your new log splitter easy and safe to operate and with proper care, it will give you many years of dependable service.



CAUTION: CAREFULLY READ THROUGH THIS ENTIRE OPERATOR'S MANUAL BEFORE USING YOUR NEW LOG SPLITTER. TAKE SPECIAL CARE TO HEED THE CAUTIONS AND WARNINGS.

GUARANTEE

This product is guaranteed against faulty manufacture for a period of 12 months from the date of purchase. Please keep your receipt which will be required as proof of purchase.



This guarantee is invalid if the product is found to have been abused or tampered with in any way, or not used for the purpose for which it was intended.

Faulty goods should be returned to their place of purchase, no product can be returned to us without prior permission.

This guarantee does not effect your statutory rights.

SAFETY SYMBOLS

The following symbols represent important information about the product or instructions on its use.

	Read these instructions in full before using the machine.		Dispose of any used oil in an environment-friendly way.
	Wear safety footwear!		Do not use in the rain.
	Wear protective gloves!		Danger! Keep clear of moving parts!
	Wear eye protection!		Do not remove jammed logs with your hands.
	Wear hearing protection!		Before starting any repair maintenance or cleaning, always disconnect the power.
	Keep your work space tidy! Untidiness may result in accidents.		Avoid injury from the movement of the splitting blade
	Do not remove or tamper with any protection or safety device.		Keep bystanders away from the working area.

GENERAL SAFETY RULES



WARNING: READ ALL OF THESE INSTRUCTIONS. FAILURE TO FOLLOW ALL INSTRUCTIONS LISTED BELOW MAY RESULT IN ELECTRIC SHOCK, FIRE AND/OR SERIOUS INJURY. SAVE THESE INSTRUCTIONS FOR FUTURE REFERENCE.

WORK AREA

1. **Keep the work area clean and well lit.** Cluttered and dark areas invite accidents.
2. **Do not operate log splitters in explosive atmospheres, such as in the presence of flammable liquids, gases or dust.** Log splitters create sparks which may ignite the dust or fumes.
3. **Keep children and bystanders away while operating the log splitter.** Distractions can cause you to lose control.
4. **The surface must be perfectly level to prevent the machine from moving during operation.**

ELECTRICAL SAFETY

1. **The log splitters plug must match the outlet. Never modify the plug in any way.** Unmodified plugs and matching outlets will reduce risk of electric shock.
2. **Avoid body contact with earthed or grounded surfaces such as pipes, radiators, ranges and refrigerators.** There is an increased risk of electric shock if your body is earthed or grounded.
3. **Do not expose log splitters to rain or wet conditions.** Water entering a log splitter will increase the risk of electric shock.
4. **Do not abuse the cord. Never use the cord for carrying, pulling or unplugging the log splitter. Keep cord away from heat, oil, sharp edges or moving parts.** Damaged or entangled cords increase the risk of electric shock.
5. **When operating the log splitter outdoors, use an extension cord suitable for outdoor use.** Use of a cord suitable for outdoor use reduces the risk of electric shock.
6. **Do not leave the log splitter unattended when plugged in to the mains supply.**

PERSONAL SAFETY

1. **Stay alert, watch what you are doing and use common sense when operating a log splitter. Do not use the log splitter while you are tired or**

under the influence of drugs, alcohol or medication. A moment of inattention while operating log splitters may result in serious personal injury.

2. **Use safety equipment. Always wear eye protection.** Safety equipment such as non-skid safety shoes, close fitting clothing and suitable work gloves should always be used.
3. **Avoid accidental starting. Ensure the switch is in the off position before plugging in.**
4. **Do not overreach. Keep proper footing and balance at all times.** This enables better control of the log splitter in unexpected situations.
5. **Dress properly. Do not wear loose clothing or jewellery. Keep your hair, clothing and gloves away from moving parts.** Loose clothes, jewellery or long hair can be caught in moving parts.

USAGE AND CARE

1. **Do not force the log splitter.** It will do the job better and safer at the rate for which it was designed.
2. **Disconnect the plug from the power source before making any adjustments, changing accessories, or storing the log splitter.** Such preventive safety measures reduce the risk of starting the log splitter accidentally.
3. **Store the log splitter out of the reach of children and do not allow persons unfamiliar with log splitters or these instructions to operate the log splitter.** Log splitters are dangerous in the hands of untrained users.
4. **Maintain the log splitter. Check for misalignment or binding of moving parts, breakage of parts and any other condition that may affect the log splitters operation. If damaged, have the log splitter repaired before use.** Many accidents are caused by poorly maintained power tools.
5. **Keep cutting tools sharp and clean.** Properly maintained cutting tools with sharp cutting edges are less likely to bind and are easier to control.

SERVICE

1. **Have your log splitter serviced by a qualified repair person using only identical replacement parts.** This will ensure that the safety of the log splitter is maintained.

LOG SPLITTERS SPECIFIC WARNINGS

UNDERSTAND YOUR LOG SPLITTER

- Read and understand the owner's manual and labels affixed to the log splitter. Learn its limitations as well as the specific potential hazards.

DRUGS, ALCOHOL AND MEDICATION

- Do not operate the log splitter while under the influence of drugs, alcohol, or any medication that could affect your ability to use it properly.

AVOID DANGEROUS WORKING CONDITIONS

- Always operate your log splitter on dry, solid, level ground. Never operate your log splitter on slippery, wet, muddy, or icy surfaces. The location you choose should be free from any tall grass, brush, or other interferences.
- There should be plenty of room for handling.
- Keep your work area clean and well lit. Cluttered areas invite injuries. To avoid tripping, do not leave tools, logs, or other components laying around the work area.
- Do not use the log splitter in wet or damp areas or expose it to rain.
- Do not use it in areas where fumes from paint, solvents or flammable liquids pose a potential hazard.

INSPECT YOUR LOG SPLITTER

- Check your log splitter before turning it on. Keep guards in place and in working order.
- Replace damaged, missing or failed parts before using it.
- Make sure all nuts, bolts, screws, hydraulic fittings etc. are securely tightened.
- Always check the oil level in the hydraulic oil tank.
- Never operate your log splitter when it is in need of repair or is in poor mechanical condition.

DRESS PROPERLY

- Do not wear loose clothing, gloves, neckties or jewelry (rings, wrist watches). They can be caught in moving parts. Protective electrically non-conductive gloves and non-skid footwear are recommended when working. Wear protective hair covering to contain long hair, preventing it from get caught in machinery.

PROTECT YOUR EYES AND FACE

- Any log splitter may throw foreign objects into the eyes. This can cause permanent eye damage. Always wear safety goggles. Everyday eyeglasses have only impact resistant lenses. They are not safety glasses.

EXTENSION CABLES

- Improper use of extension cables may cause inefficient operation of the log splitter which can result in overheating.
- Be sure the extension cable is no longer than 10m and its section is no less than 2.5mm² to allow sufficient current flow to the motor.

AVOID ELECTRIC SHOCK

- Check that the electric circuit is adequately protected and that it corresponds with the power, voltage and frequency of the motor.
- Never open the switch / plug box. Should this be necessary, contact a qualified electrician.
- Make sure your fingers do not touch the plug's metal prongs when plugging or unplugging the log splitter.
- Avoid excessive bending and twisting of the connection between the power cord of the British plug and the junction box.

PREVENT FIRES

- Do not smoke or have open flames when operating or refilling the log splitter with oil.
- Never operate the log splitter near a flame or spark. Oil is flammable.

KEEP BYSTANDERS AWAY

- Allow only one person to load and operate the log splitter.
- Always keep bystanders, including visitors, children and pets away from the work area, especially when the log splitter is in use.
- Only the operator should stand near the machine during use.
- Children should not be allowed to operate the machine.
- All operators should have the necessary training and skills to perform the functions properly and safely.

INSPECT YOUR LOG

- Never attempt to split logs containing nails, wire or debris.
- Always make sure that both ends of the log you are splitting are cut as square as possible. This will prevent the log from sliding out of position while under pressure. Branches must be cut off flush with the trunk.

DON'T OVERREACH

- Keep proper footing and balance at all times.
- Never stand on the log splitter.
- Serious injury could occur if the machine tips over.
- Do not store anything above or near the log splitter where a person might stand on the log splitter to reach it.

AVOID INJURY FROM UNEXPECTED ACCIDENT

- Do not straddle or reach across the splitting area when operating the log splitter.
- Never pile logs to be split in a manner that will cause you to reach across the log splitter.
- Only use your hands to operate the control levers. Never use your foot, knee, a rope, or any other extension device.
- Always pay full attention to the movement of the wedge ram.
- Never attempt to load your log splitter while the ram is in motion.
- Keep hands out of the way of all moving parts.
- Never try to split two logs on top of each other. One of them may fly up and hit you.

PROTECT YOUR HANDS

- When the ram of the log splitter is in the return mode, keep your hands off the machine – the log splitter is designed to automatically stop when the cylinder is fully retracted.
- Keep your hands away from splits and cracks which open in the log. They may close suddenly and crush or amputate your hands.
- Do not remove jammed logs with you hands.

DON'T FORCE THE TOOL

- It will do a better and safer job at its design rate.
- Don't use log splitter for a purpose for which it was not intended.
- Do not, under any circumstances, alter your log splitter. This equipment was designed and engineered to be used in accordance with the operating instructions. Altering the equipment, or using the equipment in such a way as to circumvent its design capabilities and capacities, could result in serious or fatal injury and will void the warranty.
- Never try to split logs larger than those indicated in the specifications table on page 10. This is dangerous and may damage the machine.

NEVER LEAVE LOG SPLITTER RUNNING UNATTENDED

- Don't leave log splitter until it has come to a complete stop

DISCONNECT POWER

- Unplug when not in use, before making adjustments, cleaning, or working on the log splitter.

MAINTAIN YOUR LOG SPLITTER WITH CARE

- Always clean the log splitter after each use.
- Keep the log splitter clean and free from debris for best and safest performance.
- Control levers and the power switch must be kept clean, dry and free from oil and grease at all times.

PROTECT THE ENVIRONMENT

- Take any used oil to an authorized collection point. Do not discharge into drains, soil or water.

MAKE THE WORKSHOP CHILDPROOF

- Lock the workshop. Store the log splitter away from children and others not qualified to use it.

SPECIAL WARNINGS & INSTRUCTIONS

The splitting operation of the machine is designed to be activated by one person. While there is the possibility that additional operators could be working with the machine (e.g. for loading and unloading), only one operator should perform splitting operations:

- Never attempt to remove a log which has got stuck on the wedge by hand. Lower the wedge until the log is completely split.
- If a log becomes stuck on the wedge at the bottom position, press the handle with one hand and turn off the machine with the other hand. Slightly knock the log by hammer to free it.

SPECIFICATIONS

Motor	230V @ 50Hz / 1 Ph	
Input Wattage	3000W	
Duty Cycle	S6 40%*	
Log Size Capacity	Diameter	8-30 cm
	Length	10-55 cm
Maximum Force	6000 kg	
Hydraulic Pressure	21.6 Mpa	
Hydraulic Oil Capacity	3.5 L	
Ram Travel	49.5 cm	
Speed	Forward	3.6 cm/sec
	Retract	16.5 cm/sec
Noise Pressure Level (LpA)	under no load;	78.8 dbA
	under full load	89.8 dbA
Vibration	<2.5 m/s ²	
Dimensions	Length	84 cm
	Width	91.5 cm
	Height	149.5 cm
Weight	98.2 kg	

*This product is designed so that the motor may be run under load for an accumulated period of 4 minutes only and off load for an accumulated period of 6 minutes in any 10 minute period.

ELECTRICAL CONNECTIONS

Connect the mains lead to a standard, 230 Volt (50Hz) electrical supply through an approved 13 amp BS 1363 plug, or a suitably fused isolator switch.

WARNING: THIS APPLIANCE MUST BE EARTHED



IMPORTANT: The wires in the mains lead are coloured in accordance with the following code:

Green & Yellow	-	Earth
Blue	-	Neutral
Brown	-	Live

As the colours of the flexible lead of this appliance may not correspond with the coloured markings identifying terminals in your plug proceed as follows:

- Connect GREEN & YELLOW wire to terminal marked with a letter "E" or Earth symbol "⏚".
- Connect BROWN wire to terminal marked with a letter "L"
- Connect BLUE wire to terminal marked with a letter "N"

If this appliance is fitted with a plug which is moulded onto the electric cable (i.e. non-rewireable) please note:

1. The plug must be thrown away if it is cut from the electric cable. There is a danger of electric shock if it is subsequently inserted into a socket outlet.
2. Never use the plug without the fuse cover fitted.
3. When replacing a detachable fuse carrier, ensure the correct replacement is used (as indicated by marking or colour code).
4. Replacement fuse covers can be obtained from your local dealer or most electrical stockists.

FUSE RATING

The fuse in the plug must be replaced with one of the same rating (13 amps) and this replacement must be ASTA approved to BS1362.

We strongly recommend that this machine is connected to the mains supply via a Residual Current Device (RCD)

If in any doubt, consult a qualified electrician. DO NOT attempt any repairs yourself.

KNOW YOUR MACHINE

Transport Handle

Split Wedge

Ram

Adjustable Log Holder

Support Table

Motor

Base Cover

Wheels

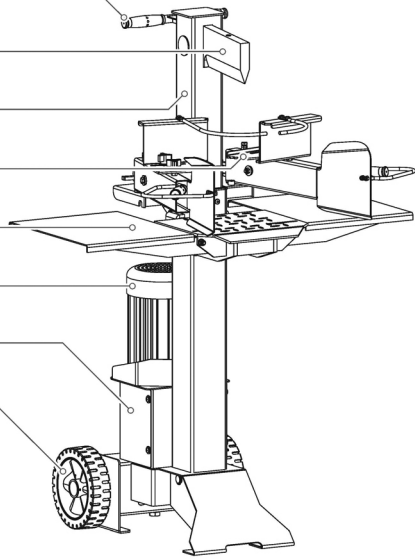

Ram Travel Adjusting Rod

Control Lever

Side Arm Frame

Control Levers Connection Bracket

Plug & switch





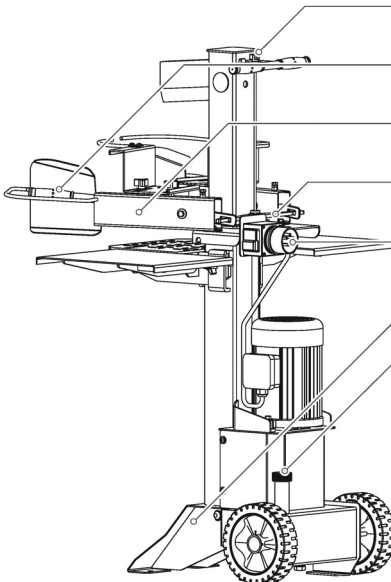



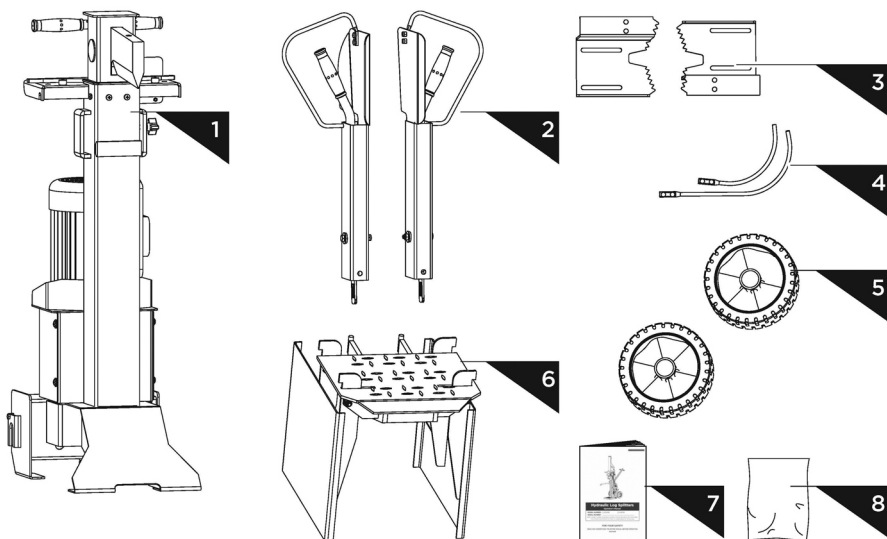



























Base

Oil Tank Filler /Air Bleeder



CONTENTS OF THE BOXES



1	Log splitter frame	5	Wheels (1 Pair)																												
2	Control Lever and Guard Assembly (1 Pair)	6	Support Table																												
3	Adjustable Log Holder (1 Pair)	7	Operating manual																												
4	Retainer 1 and 2	8	Hardware Bag, containing <table border="1" data-bbox="554 1013 983 1372"> <tbody> <tr> <td></td> <td></td> <td>× 2</td> <td></td> </tr> <tr> <td></td> <td></td> <td>× 2</td> <td></td> </tr> <tr> <td></td> <td></td> <td>× 2</td> <td>A</td> </tr> <tr> <td></td> <td></td> <td>× 2</td> <td></td> </tr> <tr> <td></td> <td></td> <td></td> <td>M10 × 25 × 2 B</td> </tr> <tr> <td></td> <td></td> <td></td> <td>M6 × 16 × 4 C</td> </tr> <tr> <td></td> <td></td> <td></td> <td>× 4</td> </tr> </tbody> </table>			× 2				× 2				× 2	A			× 2					M10 × 25 × 2 B				M6 × 16 × 4 C				× 4
		× 2																													
		× 2																													
		× 2	A																												
		× 2																													
			M10 × 25 × 2 B																												
			M6 × 16 × 4 C																												
			× 4																												

ASSEMBLY

WHEELS

1. Loosen the bolt on the axle mounting bracket by turning it counterclockwise, until the axle can be inserted into the bracket.
2. Insert the axle into the mount bracket.
3. Tighten the bolt in the mounting bracket to secure the axle.
4. Slide the wheel on to the axle and secure in position with a washer and split pin from outside. spread the split pin prongs in opposite directions.
5. Put on the wheel cap.
6. Repeat the same steps to install the wheel at the other side.

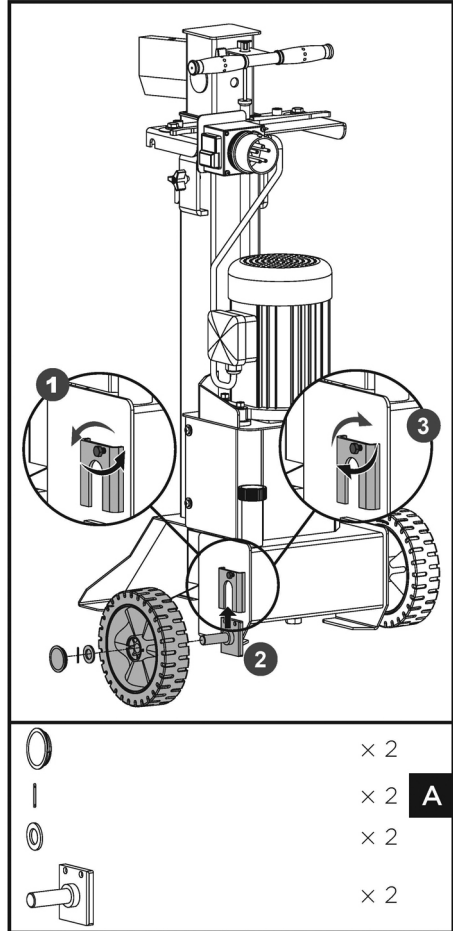

SUPPORT TABLE

1. Loosen the star knob on the mounting bracket by turning it counterclockwise.
2. Unfold the log support table, so that the three parts of it are level.
3. Insert the hooks of the log support table into the mounting brackets.
4. Tighten the star knob to secure the table..

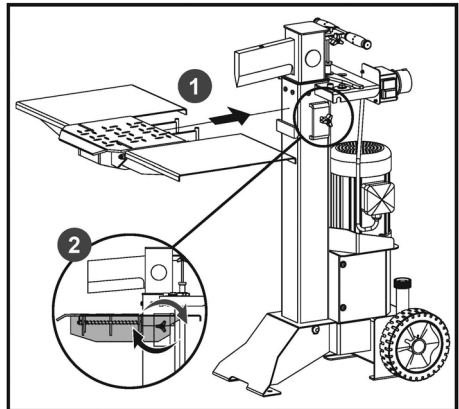
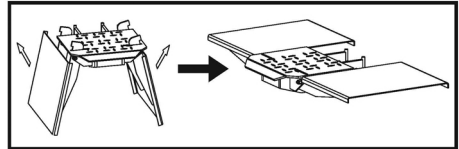
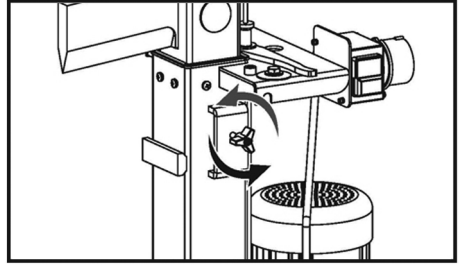

CONTROL LEVER

1. Insert an M10 bolt with a washer through the hole in the side arm (1)
2. Pass the control lever through the slot in the control handle (2)
3. Position a large washer between the side arm and the main frame
 - This will act as a bearing
4. Secure the side arm assembly to the frame with an M10 nut & washer (3).
 - Do not overtighten.
5. Check the side arm assembly for free movement and repeat the installation with the opposite side arm assembly.

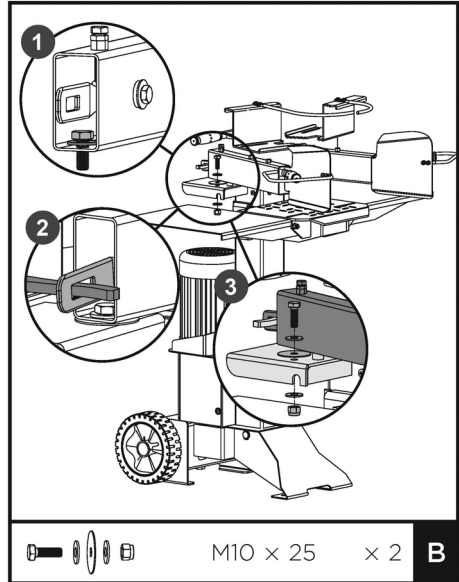

ADJUSTABLE LOG HOLDER

1. Secure the retaining bars to the log holder with the M6x16 bolts, nuts and washers.
 - Ensure the direction of the retaining bars are as shown in the picture.
2. Fix the log holders to the side arm frame with the star knobs and washers.

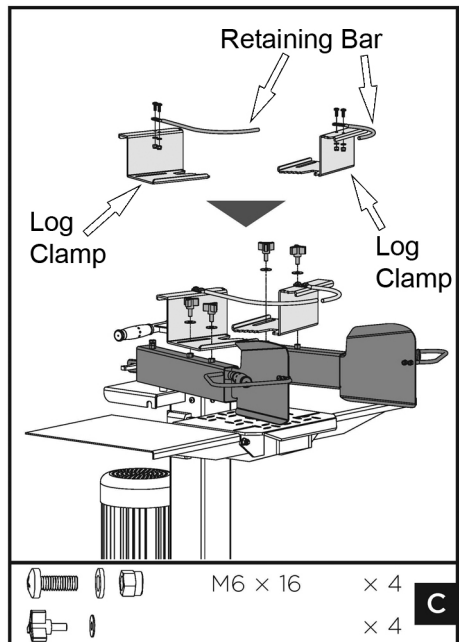

TRANSPORT

MOVING BY HAND

To move the log splitter to the work site.

1. Hold the handle (A) and tilt the log splitter back slightly onto the wheels.
 - Make sure the oil filler cap is tight.



WARNING: THE LOG SPLITTER IS VERY HEAVY, TAKE CARE WHEN MOVING IT TO A NEW LOCATION.

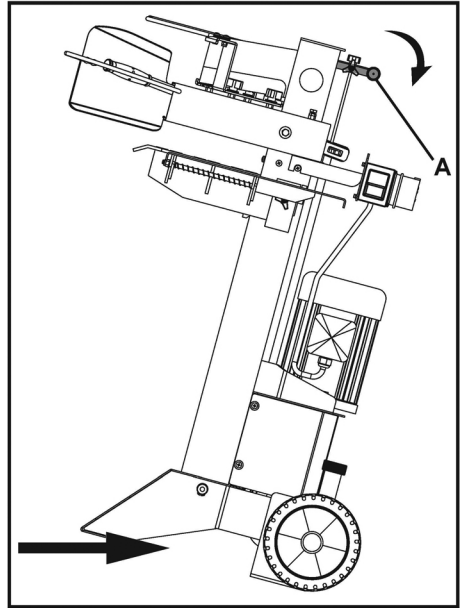

LIFTING WITH A CRANE



WARNING: IF USING A CRANE, ATTACH A HOIST SLING AT LIFTING POINT (A).



WARNING: FOR LONG DISTANCE TRANSPORT, SECURE THE LOG SPLITTER TO PREVENT MOVEMENT.

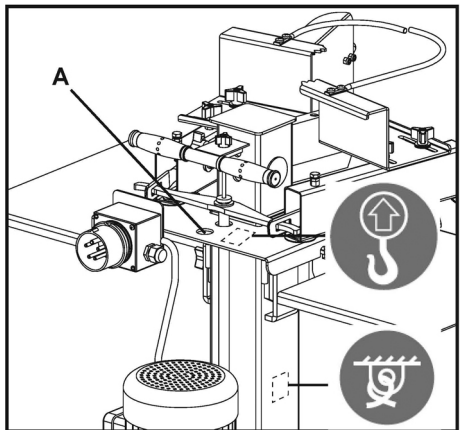

SPLITTER OPERATION

Before operation, attach the machine to a level floor using M10 hold down bolts (not supplied).

1. Plan your work site.
 - Work safely and save effort by planning your work before hand.
 - Have your logs positioned where they can be easily reached.
 - Have a site ready to stack the split wood or load it onto a nearby truck or other carrier.
2. Prepare the logs for splitting.
 - This splitter will split logs up to 550mm in length and 300mm in diameter.

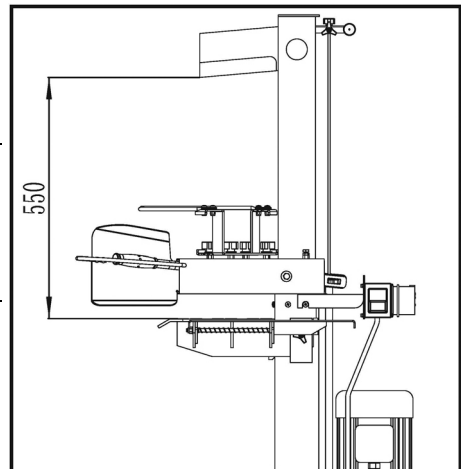
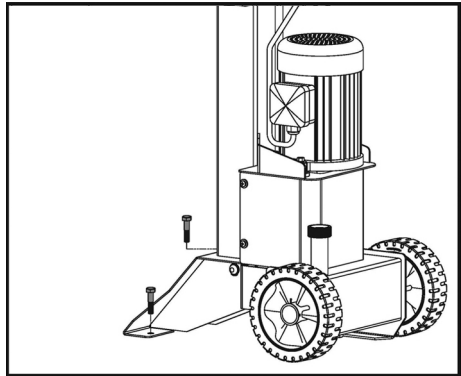

WARNING: DO NOT TRY TO SPLIT GREEN LOGS. DRY, SEASONED LOGS SPLIT MUCH MORE EASILY AND WILL NOT JAM AS FREQUENTLY AS GREEN WOOD.

3. Apply a thin layer of grease to the surfaces of the ram before operation
 - This will increase the durability of the ram.
4. Route the power cable in a way that safeguards against tripping on or damaging the cable, during the work session. Protect the power cable from impact, pulling or contact with corrosive materials.

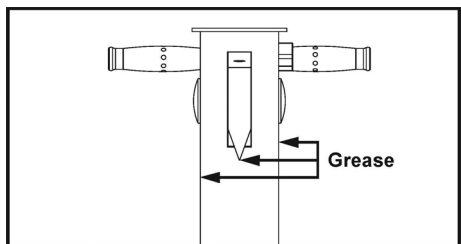

5. Loosen the oil filler cap a few turns before use to allow air into the oil tank during use.
 - Retighten the oil filler cap when you have finished using or moving the log splitter.
6. While operating under extremely low temperature, keep the log splitter running under no load for 15 minutes to preheat the hydraulic oil.
7. Before initial operation, make sure the two-handed operation is functioning correctly by:
 - (1) Lower both control levers. Make sure that the splitting wedge lowers to approx 5cm above the highest table position.
 - (2) Release one of the levers. Confirm that the splitting wedge remains in its current position.
 - (3) Release both levers. The ram must rise to the highest position automatically.
8. To set the ram stroke take the following steps:

- (1) Move splitting wedge to the desired position. The upper position of the ram wedge travel must be about 3~5cm over the logs to be split.
- (2) Release one of the control levers.
- (3) Release the Star knob (A). Raise the Adjusting Rod (B) until it is stopped by the spring inside. Tighten the Star knob(A).
- (4) Release both control levers.
- (5) Check upper position of splitting wedge.

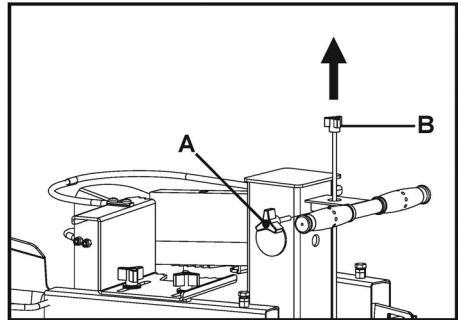

9. Put the log onto the support table vertically. Make sure that the wedge and support table touch the log squarely on the ends. Never try to split a log at an angle.



WARNING: ALWAYS SPLIT LOGS LENGTHWAYS. DO NOT PLACE LOG ACROSS THE LOG SPLITTER FOR SPLITTING. IT CAN BE DANGEROUS AND CAN SERIOUSLY DAMAGE THE MACHINE.

10. Adjust the Log Holders (A) according to the diameter of the log to obtain most comfortable Control Lever angle.

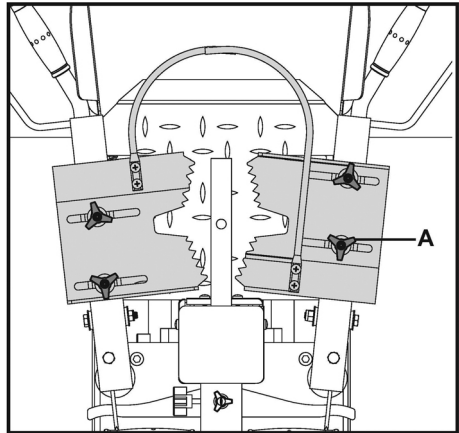

11. Hold the log with log holders
Lower the levers to start the splitting.

- Releasing either lever stops the motion of the splitting wedge.
- Release both handles to return the splitting wedge to the upper position.

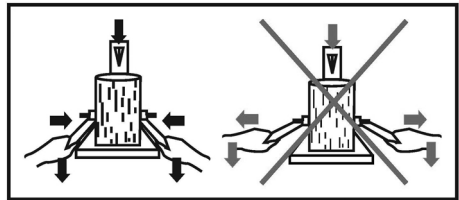

12. Stack the split logs as you work. This will provide a safer work area, by keeping it uncluttered and avoiding the danger of tripping, or damaging the power cable.



WARNING: ACCUMULATED SPLIT WOOD AND WOOD CHIPS CAN CREATE A HAZARDOUS WORK ENVIRONMENT. NEVER CONTINUE TO WORK IN A CLUTTERED WORK AREA WHICH MAY CAUSE YOU TO SLIP, TRIP OR FALL.

MAINTENANCE



WARNING: MAKE SURE THAT THE LOG SPLITTER IS SWITCHED OFF AND DISCONNECTED FROM THE MAINS SUPPLY BEFORE STARTING ANY CLEANING OR MAINTENANCE PROCEDURES.

HYDRAULIC SYSTEM

- Low oil levels can damage the oil pump.
- The oil should be completely changed once a year.
- Make sure that no dirt or debris finds its way into the oil tank.
- Collect used oil and recycle responsibly.
- Following an oil change, activate the log splitter a few times without actually splitting.

REPLACING HYDRAULIC OIL

1. Remove the oil filler cap

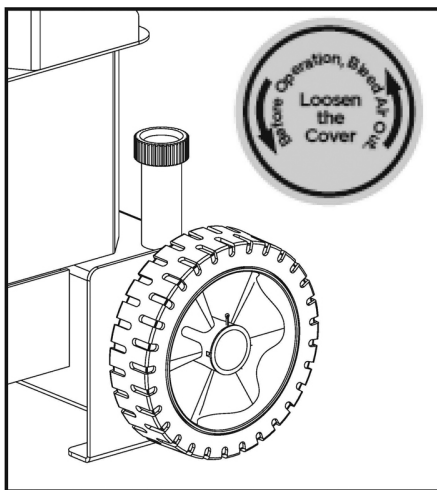

2. Check the oil level with the dipstick.

- Oil Level should be between the min and max marks on the dipstick.

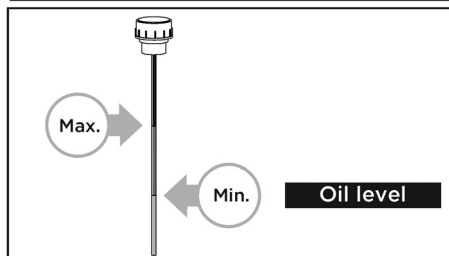

3. Place an oil pan beneath the oil drain plug.
4. Remove the oil drain plug and allow the oil to drain into the oil pan.
5. Replace the oil drain plug.
6. Fill the oil tank with suitable hydraulic oil available from your Clarke dealer
 - 1L - Part no: 3050830,
 - 5L - Part no: 3050835

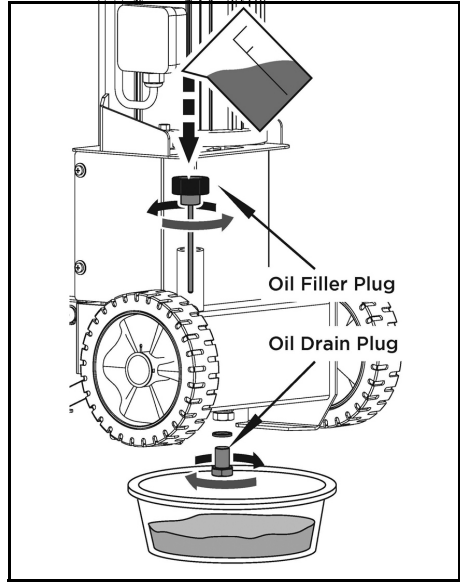

SHARPENING THE WEDGE

This log splitter is equipped with a reinforced splitting wedge. After long periods of operation, and when required sharpen the wedge using a fine toothed file removing any burrs or flat spots on the edge.

TROUBLESHOOTING

PROBLEM	CAUSE	REMEDY
Motor does not start.	No power being supplied	Check mains fuse
	Extension lead is defective	Unplug, check and replace if necessary
	Switch is defective	Return the log splitter to your local Clarke dealer for servicing.
Log splitter does not work while the motor is running.	Air bleeder is not open	Open oil bleeder.
	Control levers are bent	Repair the bent control levers
	Low oil level	Check and refill hydraulic oil.
Log splitter works but with abnormal noise and vibration.	Low oil level	Check and refill hydraulic oil.

DECLARATION OF CONFORMITY



Clarke[®]
INTERNATIONAL

Hemnall Street, Epping, Essex CM16 4LG

DECLARATION OF CONFORMITY

This is an important document and should be retained.

We hereby declare that this product(s) complies with the following directive(s):

2014/30/EU *Electromagnetic Compatibility Directive.*

2006/42/EC *Machinery Directive.*

2011/65/EU *Restriction of Hazardous substances.*

The following standards have been applied to the product(s):

EN 609-1:2017, EN 60204-1:2006+A1:2009+AC: 2010, EN 60034-1:2010, EN 55014-1:2017,

EN 61000-3-2:2014, EN6100-3-11:2000, EN 55014-2:2015.

The technical documentation required to demonstrate that the product(s) meet(s) the requirement(s) of the aforementioned directive(s) has been compiled and is available for inspection by the relevant enforcement authorities.

The CE mark was first applied in: 2018

Product Description: 6 Ton Vertical Log Splitter

Model number(s): Log Buster V6

Serial / batch Number: N/A

Date of Issue: 15/11/2018

Signed:

J.A. Clarke
Director

A SELECTION FROM THE VAST RANGE OF

Clarke®

QUALITY PRODUCTS

AIR COMPRESSORS

From DIY to industrial, Plus air tools, spray guns and accessories.

GENERATORS

Prime duty or emergency standby for business, home and leisure.

POWER WASHERS

Hot and cold, electric and engine driven - we have what you need

WELDERS

Mig, Arc, Tig and Spot. From DIY to auto/industrial.

METALWORKING

Drills, grinders and saws for DIY and professional use.

WOODWORKING

Saws, sanders, lathes, mortisers and dust extraction.

HYDRAULICS

Cranes, body repair kits, transmission jacks for all types of workshop use.

WATER PUMPS

Submersible, electric and engine driven for DIY, agriculture and industry.

POWERTOOLS

Angle grinders, cordless drill sets, saws and sanders.

STARTERS/CHARGERS

All sizes for car and commercial use.



PARTS & SERVICE: 0208 988 7400

E-mail: Parts@clarkeinternational.com or Service@clarkeinternational.com

SALES: UK 01992 565333 or Export 00 44 (0)1992 565335

Clarke® INTERNATIONAL Hemnall Street, Epping, Essex CM16 4LG
www.clarkeinternational.com